

w w w . t u n g a l o y . c o m

Новая серия круглых пластин и державок с точной фиксацией.

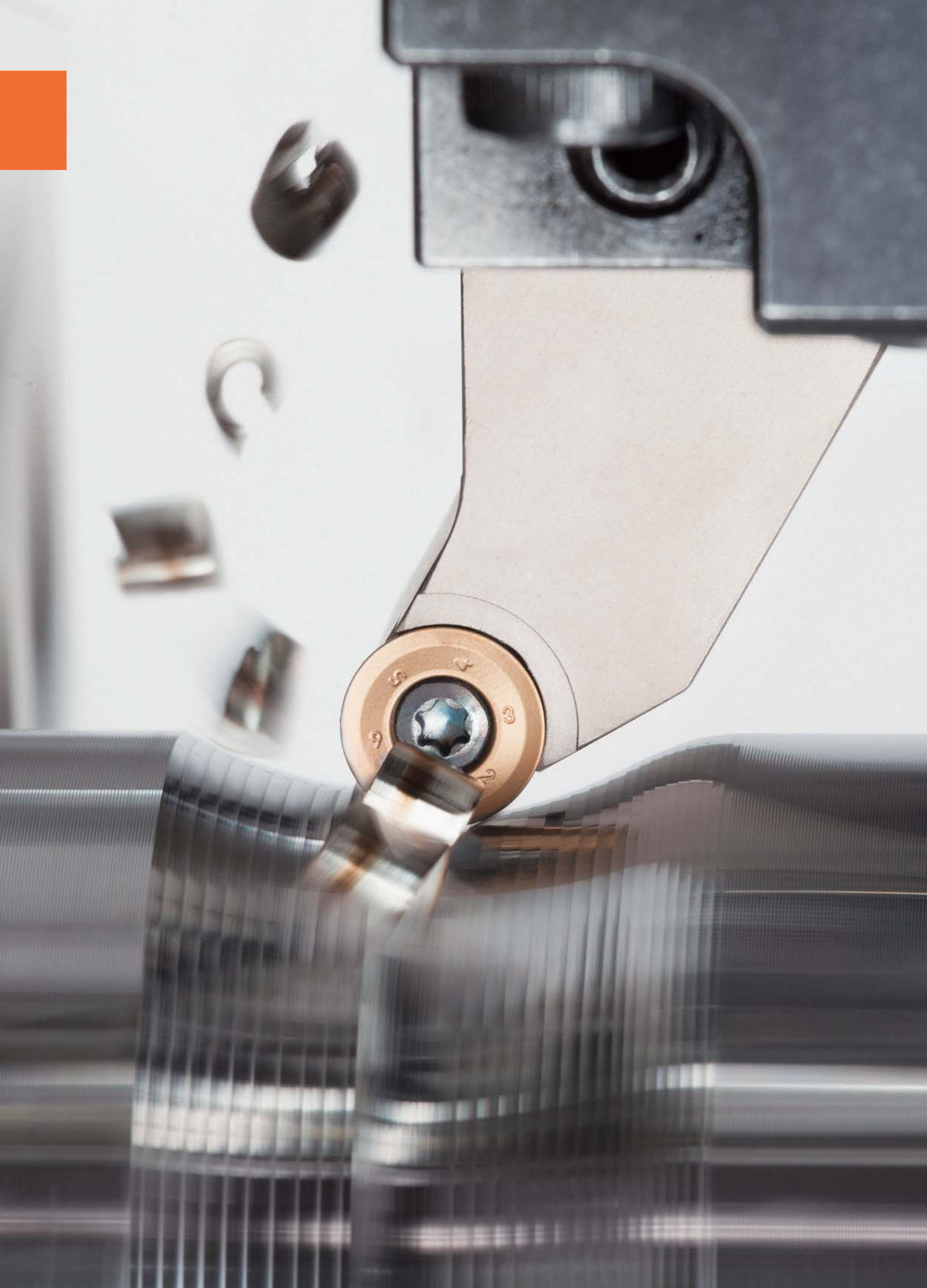

FIXRTURN TUNGALOY

* доступны круглые пластины с точной фиксацией в 6 положениях.

* $a_p \leq 2$ мм.

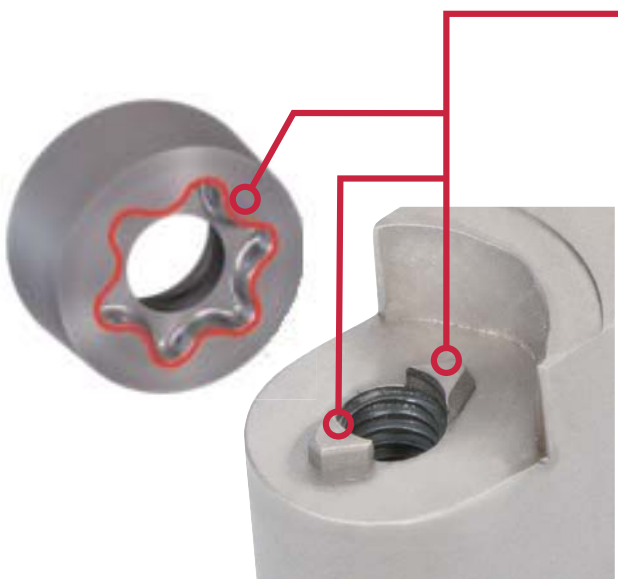

- Выемка на нижней поверхности пластины и приливы на державке.
- Повернуть пластину можно без снятия винта!
- Круглая пластина применима для черновой обработки на высокой подаче!
Макс. подача : $f = 1.0$ мм/об.
 $a_p \leq 2$ мм.)
- FixRTurn provides the same cutting performance of the conventional toolholder and flat bottom inserts.
- Index numbers are shown on the insert's rake face

● Compatibility with conventional tools

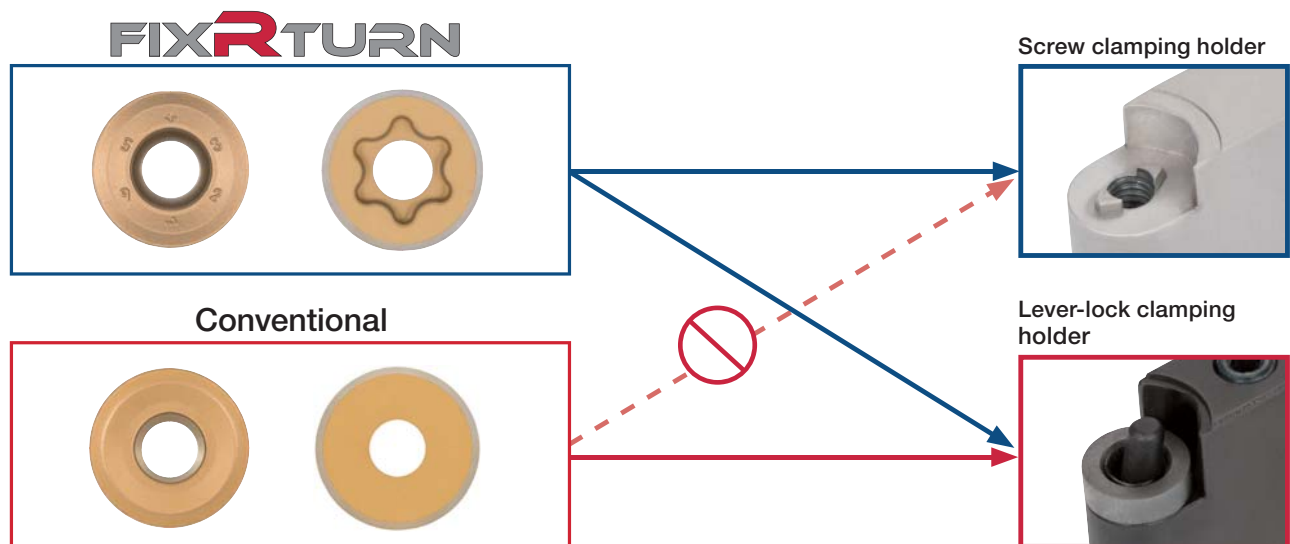

Note: conventional insert with flat bottom is NOT applicable for FixRTurn toolholders.

● Chipbreaker

6RM type



General purpose chipbreaker with toughness and sharpness

6RS type

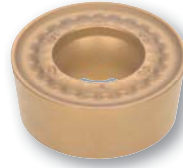

For lower cutting force with sharp cutting edge

● Application range



Workpiece-material : SCM440
 Cutting speed : $V_c = 250$ m/min
 Machining : External turning (continuous)
 Coolant : Wet

*For 6-index use, depth of cut should be under 2.0 mm.

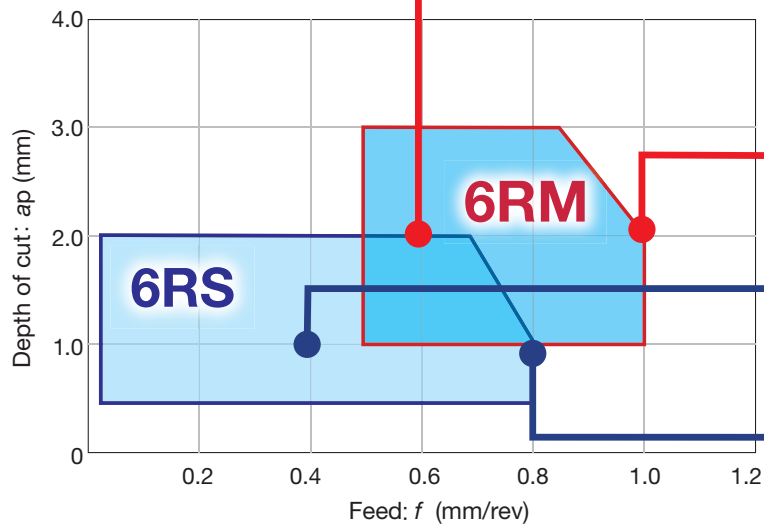

● Cutting performance

■ Continuous machining

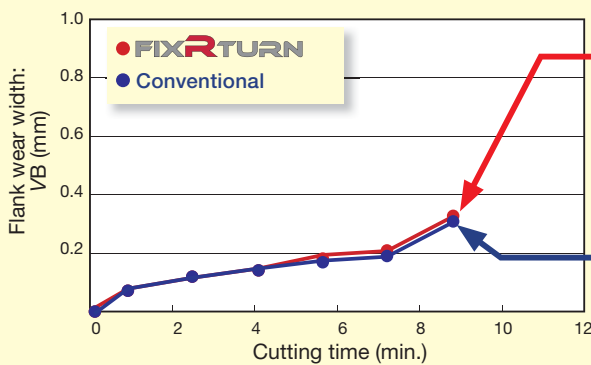

FIXRTURN



Conventional



P Alloy steel
 SCM440 (290 ~ 310HB)

Insert : RCMT1204M0-6RM
 T9125
 Cutting speed : $V_c = 200$ m/min
 Feed : $f = 0.8$ mm/rev
 Depth of cut : $a_p = 2.0$ mm
 Coolant : Wet

The same level of wear resistance as that of the conventional product due to exact indexing.

■ Interrupted machining

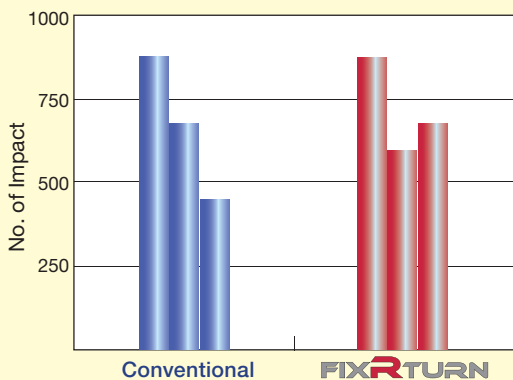

FIXRTURN



Conventional



P Alloy steel
 SCM440 (290 ~ 310HB)

Insert : RCMT1204M0-6RM
 T9125
 Cutting speed : $V_c = 150$ m/min
 Feed : $f = 0.3$ mm/rev
 Depth of cut : $a_p = 2.0$ mm
 Coolant : Wet

Stable clamping rigidity even in interrupted cutting.

● Inserts

| Chipbreaker | | | Grades | | | | Dimensions (mm) | | | | |
|-------------------------|-------------------------------|----------|-----------------------|--------|-------|--------|-----------------|----------------------------|-----------------------|----------------------------------|---------------------------------|
| Application | Appearance (Cross section) | $f - ap$ | Cat. No | Coated | | Cermet | | I.C.dia $\varnothing d$ | Thick- ness s | Hole dia $\varnothing d_1$ | Corner radius $r\epsilon$ |
| | | | | T9115 | T9125 | NS9530 | | | | | |
| Low cutting force | 6RS | | RCMT1204M0-6RS | ● | ● | ● | | 12 | 4.76 | 5.16 | - |
| | | | | | | | | | | | |
| General use | 6RM | | RCMT1204M0-6RM | ● | ● | ● | | 12 | 4.76 | 5.16 | - |
| | | | | | | | | | | | |

● External toolholders

SRDCN

External turning and profiling

S-type (Positive rake, screw-on system)

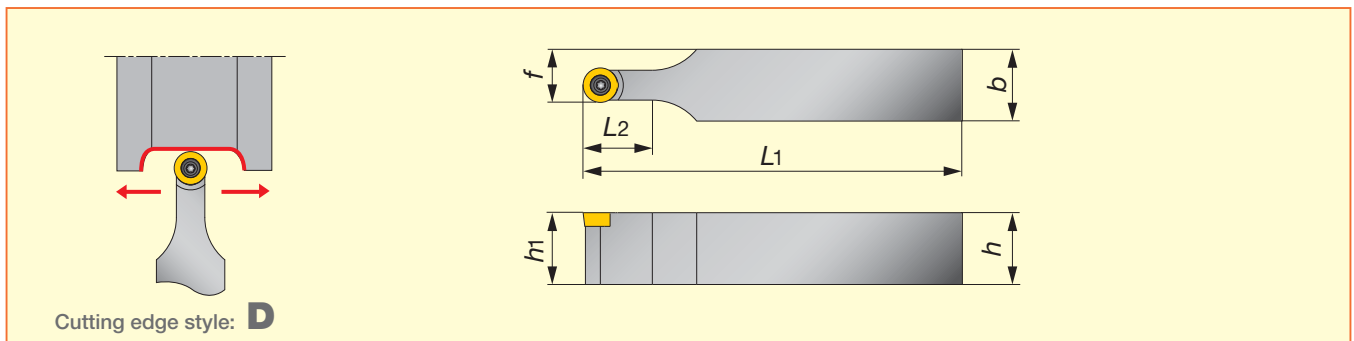

| Cat. No | Stock | Dimensions (mm) | | | | | | | Insert | Parts | | | Torque (N·m) |
|------------------------|-------|-----------------|-----|-------|-------|-------|------|-------|--------------|--------|--------------------|-------|-----------------|
| | | h | b | L_1 | L_2 | h_1 | f | f_2 | | Screw | Screw lubricant | Key | |
| SRDCN2525M12-6F | ● | 25 | 25 | 150 | 24.1 | 25 | 18.5 | - | RC*1204M0-6* | CSTB-4 | M-1000 | T-15F | 3.0 |

SRGCR/L

External turning and profiling

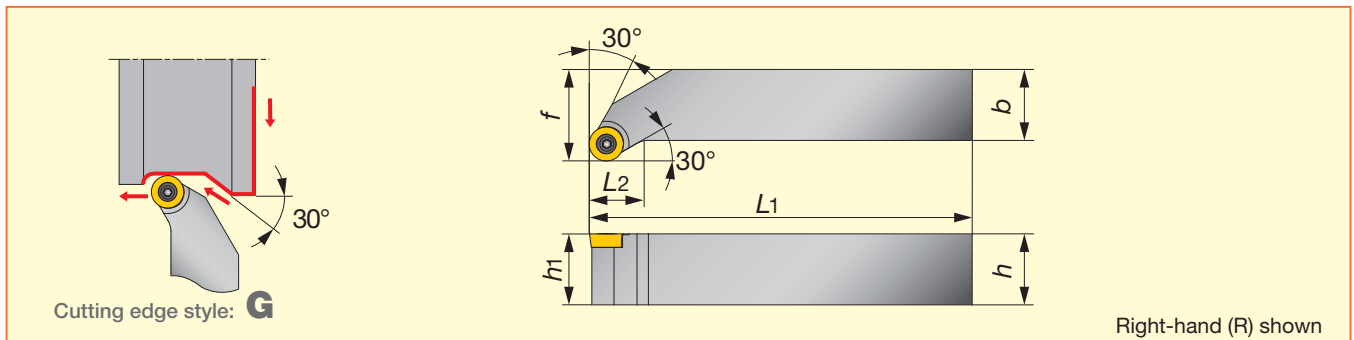

S-type (Positive rake, screw-on system)



| Cat. No | Stock | | Dimensions (mm) | | | | | | | Insert | Parts | | | Torque (N·m) |
|--------------------------|-------|---|-----------------|-----|-------|-------|-------|-----|-------|--------------|--------|--------------------|-------|-----------------|
| | R | L | h | b | L_1 | L_2 | h_1 | f | f_2 | | Screw | Screw lubricant | Key | |
| SRGCR/L2525M12-6F | ● | ● | 25 | 25 | 150 | 18.6 | 25 | 32 | - | RC*1204M0-6* | CSTB-4 | M-1000 | T-15F | 3.0 |

● : Stocked items

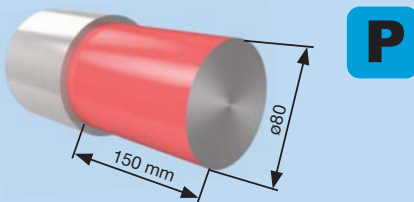
● Practical examples

| | | | |
|--------------------|------------------------------|--|--|
| Workpiece type | | Cylinder | |
| Toolholder | | SRGCL2525M12-6F | |
| Insert | | RCMT1204M0-6RM | |
| Grade | | T9115 | |
| Workpiece material | | SCM435 / 34CrMo4 | |
| | |  | |
| Cutting conditions | Cutting speed: V_c (m/min) | 200 | |
| | Feed: f (mm/rev) | 1.0 | |
| | Depth of cut: a_p (mm) | 1.0 | |
| | Machining | External turning (continuous) | |
| | Coolant | Wet | |
| Results | |  | |
| | | <p>FixRTurn allows easy indexing and also delivers excellent chip control !!</p> | |



Tungaloy Corporation (Head office)

11-1 Yoshima-Kogyodanchi
Iwaki-city, Fukushima, 970-1144 Japan
Phone: +81-246-36-8501
Fax: +81-246-36-8542
www.tungaloy.co.jp

Tungaloy America, Inc.

3726 N Ventura Drive
Arlington Heights, IL 60004, U.S.A.
Phone: +1-888-554-8394
Fax: +1-888-554-8392
www.tungaloyamerica.com

Tungaloy Canada

432 Elgin St. Unit 3
Brantford, Ontario N3S 7P7, Canada
Phone: +1-519-758-5779
Fax: +1-519-758-5791
www.tungaloy.co.jp/ca

Tungaloy de Mexico S.A.

C Los Arellano 113,
Parque Industrial Siglo XXI
Aguascalientes, AGS, Mexico 20290
Phone: +52-449-929-5410
Fax: +52-449-929-5411
www.tungaloy.co.jp/mx

Tungaloy do Brasil Ltda.

Rua dos Sabias N.104
13280-000 Vinhedo, São Paulo, Brazil
Phone: +55-19-38262757
Fax: +55-19-38262757
www.tungaloy.com/br

Tungaloy Germany GmbH

An der Alten Ziegelei 1
D-40789 Monheim, Germany
Phone: +49-2173-90420-0
Fax: +49-2173-90420-19
www.tungaloy.de

Tungaloy France S.A.S.

ZA Courtaboeuf - Le Rio
1 rue de la Terre de feu
F-91952 Courtaboeuf Cedex, France
Phone: +33-1-6486-4300
Fax: +33-1-6907-7817
www.tungaloy.fr

Tungaloy Italia S.r.l.

Via E. Andolfato 10
I-20126 Milano, Italy
Phone: +39-02-252012-1
Fax: +39-02-252012-65
www.tungaloy.it

Tungaloy Czech s.r.o.

Turanka 115
CZ-627 00 Brno, Czech Republic
Phone: +420-532 123 391
Fax: +420-532 123 392
www.tungaloy.cz

Tungaloy Ibérica S.L.

C/Miquel Servet, 43B, Nau 7
Pol. Ind. Bufalvent
ES-08243 Manresa (BCN), Spain
Phone: +34 93 113 1360
Fax: +34 93 876 2798
www.tungaloy.es

Tungaloy Scandinavia AB

S:t Lars Väg 42A
SE-22270 Lund, Sweden
Phone: +46-462119200
Fax: +46-462119207
www.tungaloy.se

Tungaloy Rus, LLC

36-D Harkovsky Lane
308009 Belgorod, Russia
Phone: +7 4722 24 00 07
Fax: +7 4722 24 00 08
www.tungaloy.co.jp/ru

Tungaloy East LLC

Stachek str., h.4, office 2, Ekaterinburg,
620017, Russia
Phone: +7-343-389-13-22
Fax: +7-343-278-94-35
www.tungaloy.co.jp/ru

Tungaloy Polska Sp. z o.o.

ul. Genewska 24
03-963 Warszawa, Poland
Phone: +48-22-617-0890
Fax: +48-22-617-0890
www.tungaloy.co.jp/pl

Tungaloy U.K. Ltd

The Technology Centre,
Wolverhampton Science Park
Glaisher Drive, Wolverhampton
West Midlands WV10 9RU, UK
Phone: +44 121 4000 231
Fax: +44 121 270 9694
www.tungaloy.co.jp/uk
salesinfo@tungaloyuk.co.uk

Tungaloy Hungary Kft

Erzsébet királyné útja 125
H-1142 Budapest, Hungary
Phone: +36 1 781-6846
Fax: +36 1 781-6866
www.tungaloy.co.jp/hu
info@tungaloytools.hu

Tungaloy Turkey

Dudullu, OSB 4. Cad No:4
34776 Umraniye Istanbul, TURKEY
Phone: +90 216 540 04 67
Fax: +90 216 540 04 87
www.tungaloy.com.tr
info@tungaloy.com.tr

Tungaloy Benelux b.v.

Tjalk 70
NL-2411 NZ Bodegraven, Netherlands
Phone: +31 172 630 420
Fax: +31 172 630 429
www.tungaloy-benelux.com

Tungaloy Croatia

Josipa Kozarca 4
10432 Bregana, Croatia
Phone: +385 1 3326 604
Fax: +385 1 3327 683
www.tungaloy.hr

Tungaloy Cutting Tool (Shanghai) Co.,Ltd.

Rm No 401 No.88 Zhabei
Jiangchang No.3 Rd
Shanghai 200436, China
Phone: +86-21-3632-1880
Fax: +86-21-3621-1918
www.tungaloy.co.jp/tots

Tungaloy Cutting Tool (Thailand) Co.,Ltd.

Interlink tower 4th Fl.
1858/5-7 Bangna-Trad Road
km.5 Bangna, Bangna, Bangkok 10260
Thailand
Phone: +66-2-751-5711
Fax: +66-2-751-5715
www.tungaloy.co.th

Tungaloy Singapore (Pte.), Ltd.

62 Ubi Road 1, #06-11 Oxley BizHub 2
Singapore 408734
Phone: +65-6391-1833
Fax: +65-6299-4557
www.tungaloy.co.jp/tspl

Tungaloy Vietnam

Unit 18, 4th Fl. Saigon Centre Building
65 Le Loi Blvd.
Dist 1, Ho Chi Minh City, Vietnam
Phone: +84-8-3827-0201
Fax: +84-8-3827-0203
www.tungaloy.co.jp/tspl

Tungaloy India Pvt. Ltd.

Indiabulls Finance Centre,
Unit # 902-A, 9th Floor,
Tower 1, Senapati Bapat Marg,
Elphinstone Road (West),
Mumbai -400013, India
Phone: +91-22-6124-8804
Fax: +91-22-6124-8899
www.tungaloy.co.jp/in

Tungaloy Korea Co., Ltd

#1312, Byucksan Digital Valley 5-cha
Beotkkot-ro 244, Geumcheon-gu
153-788 Seoul, Korea
Phone: +82-2-2621-6161
Fax: +82-2-6393-8952
www.tungaloy.co.jp/kr

Tungaloy Malaysia Sdn Bhd

50 K-2, Kelana Mall, Jalan SS6/14
Kelana Jaya, 47301
Petaling Jaya, Selangor Darul Ehsan
Malaysia
Phone: +603-7805-3222
Fax: +603-7804-8563
www.tungaloy.co.jp/my

Tungaloy Australia Pty Ltd

PO Box 2232, Rowville,
Victoria 3178, Australia
Phone: +61-3-9755-8147
Fax: +61-3-9755-6070
www.tungaloy.com.au

PT. Tungaloy Indonesia

Kompleks Grand Wisata Block AA-10 No.3-5
Cibitung
Bekasi 17510, Indonesia
Phone: +62-21-8261-5808
Fax: +62-21-8261-5809
www.tungaloy.co.jp/id



www.tungaloy.com

follow us at:

facebook.com/tungaloyjapan

twitter.com/tungaloyjapan

To see this product in action visit:

Tung-TV

www.youtube.com/tungaloycorporation

Distributed by:



DOWNLOAD
Dr. Carbide
Tungaloy



Available on the
App Store



GET IT ON
Google play



ISO 9001 Certified
QC00J0056
Tungaloy Corporation
18/10/1996

ISO 14001 Certified
EC97J1123
Tungaloy Group
Japan site and Asian
production site
26/11/1997

Produced from Recycled paper

Dec. 2015 (TJ)